

# L2034

## ■ Features of L2034 Series

- 20 characters × 4 lines
- STN gray type LCD is used
- 5 × 7 dot matrix + cursor
- 1/16 duty
- 5V single power supply

## ■ Specification

### A. Mechanical Characteristics

Item	Specifications	Unit
Module size (H×V×T) (Reflective type)	98.0×60.0×11.6	mm
Module size (H×V×T) (Built-in LED backlight type)	98.0×60.0×15.8	mm
Viewing area (H×V)	76.0×25.2	mm
Character size (5×7 dot, H×V)	2.95×4.15	mm
Dot size (H×V)	0.55×0.55	mm
Dot space	0.05	mm
Center to center dimension of mounting holes (H×V)	93.0×55.0	mm
Weight (Reflective type)	55	g
Weight (Built-in LED backlight type)	70	g

H : Horizontal, V : Vertical, T : Thickness (max.)

### B. Absolute Maximum Ratings

V<sub>SS</sub> = 0V

Item	Symbol	Conditions	Min.	Max.	Unit
Power supply voltage	V <sub>DD</sub>		-0.3	6.0	V
	V <sub>LC</sub>		V <sub>DD</sub> -12.0	V <sub>DD</sub>	V
Input voltage	V <sub>IN</sub>		-0.3	V <sub>DD</sub> +0.3	V
Operating temp.	T <sub>opr</sub>		0	+50	°C
Storage temp.	T <sub>stg</sub>		-20	+60	°C
Storage humidity		≤48hrs	+20	+85	%RH
		≤1000hrs	+20	+65	%RH

### C. Electrical Characteristics

V<sub>DD</sub> = 5V ± 5%, V<sub>SS</sub> = 0V, T<sub>a</sub> = 0°C to 50°C

Item	Symbol	Conditions	Min.	Typ.	Max.	Unit
Power supply voltage	V <sub>DD</sub>		4.75	5.00	5.25	V
	V <sub>DD</sub> -V <sub>LC</sub>		4.0	—	11.0	V
Input voltage *	High	V <sub>IH1</sub>	2.2	—	V <sub>DD</sub>	V
	Low	V <sub>IL1</sub>	0	—	0.6	V
Output voltage **	High	V <sub>OH1</sub>	-I <sub>OH</sub> = 0.205mA	2.4	—	V
	Low	V <sub>OL1</sub>	I <sub>OL</sub> = 1.2mA	—	—	0.4
Current consumption	I <sub>DD</sub>	T <sub>a</sub> = 25°C V <sub>DD</sub> = 5V V <sub>LC</sub> = 0.25V	—	2.9	4.0	mA
	I <sub>LC</sub>		—	1.2	2.0	mA
Clock oscillation frequency	f <sub>osc</sub>	Resistance oscillation	140	220	300	kHz

\* Applied to DB<sub>0</sub> ~ DB<sub>7</sub>, E, R/W, RS

\*\* Applied to DB<sub>0</sub> ~ DB<sub>7</sub>

### D. Optical Characteristics

#### D-1 Reflective type

Viewing angle : 6 o'clock (∅ = 0°), T<sub>a</sub> = 25°C, V<sub>opr</sub> = 4.75V

Item	Symbol	Conditions	Min.	Typ.	Max.	Unit
Viewing angle	θ <sub>1</sub>	C ≥ 2.0 ∅ = 0°	—	—	-15	deg.
	θ <sub>2</sub>		55	—	—	
	θ <sub>2</sub> - θ <sub>1</sub>		70	—	—	
Contrast	C	θ = 25°, ∅ = 0°	2	4	—	—
Response time (rise)	t <sub>on</sub>	θ = 0° ∅ = 0°	—	270	400	ms
Response time (fall)	t <sub>off</sub>		—	60	100	
Response time (rise)	t <sub>on</sub>	θ = 0°, ∅ = 0° T <sub>a</sub> = 0°C V <sub>opr</sub> = 5.0V	—	720	1100	ms
Response time (fall)	t <sub>off</sub>		—	170	350	

#### D-2 Transflective type

Viewing angle : 6 o'clock (∅ = 0°), T<sub>a</sub> = 25°C, V<sub>opr</sub> = 4.75V, Backlight OFF

Item	Symbol	Conditions	Min.	Typ.	Max.	Unit
Viewing angle	θ <sub>1</sub>	C ≥ 2.0 ∅ = 0°	—	—	-10	deg.
	θ <sub>2</sub>		50	—	—	
	θ <sub>2</sub> - θ <sub>1</sub>		60	—	—	
Contrast	C	θ = 25°, ∅ = 0°	2	4	—	—
Response time (rise)	t <sub>on</sub>	θ = 0° ∅ = 0°	—	270	400	ms
Response time (fall)	t <sub>off</sub>		—	60	100	
Response time (rise)	t <sub>on</sub>	θ = 0°, ∅ = 0° T <sub>a</sub> = 0°C V <sub>opr</sub> = 5.0V	—	720	1100	ms
Response time (fall)	t <sub>off</sub>		—	170	350	

### E. Recommended Operating Voltage

The recommended value of (V<sub>opr</sub>) for an ambient temperature is as follows.

V<sub>opr</sub> = V<sub>DD</sub>-V<sub>LC</sub>

Temperature (°C)	0	25	50
V <sub>opr</sub> (V)	5.00	4.75	4.50

■ STN Reflective type

Item	L203400J000
Mechanical Characteristics	A
Absolute Maximum Ratings	B
Electrical Characteristics	C
Optical Characteristics	D-1
Recommended Operating Voltage	E

F-1 Power Supply

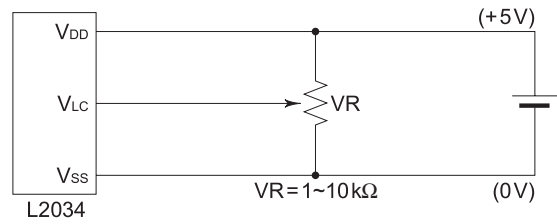

F-2 Dimensions

Unit : mm  
General tolerance : ±0.5

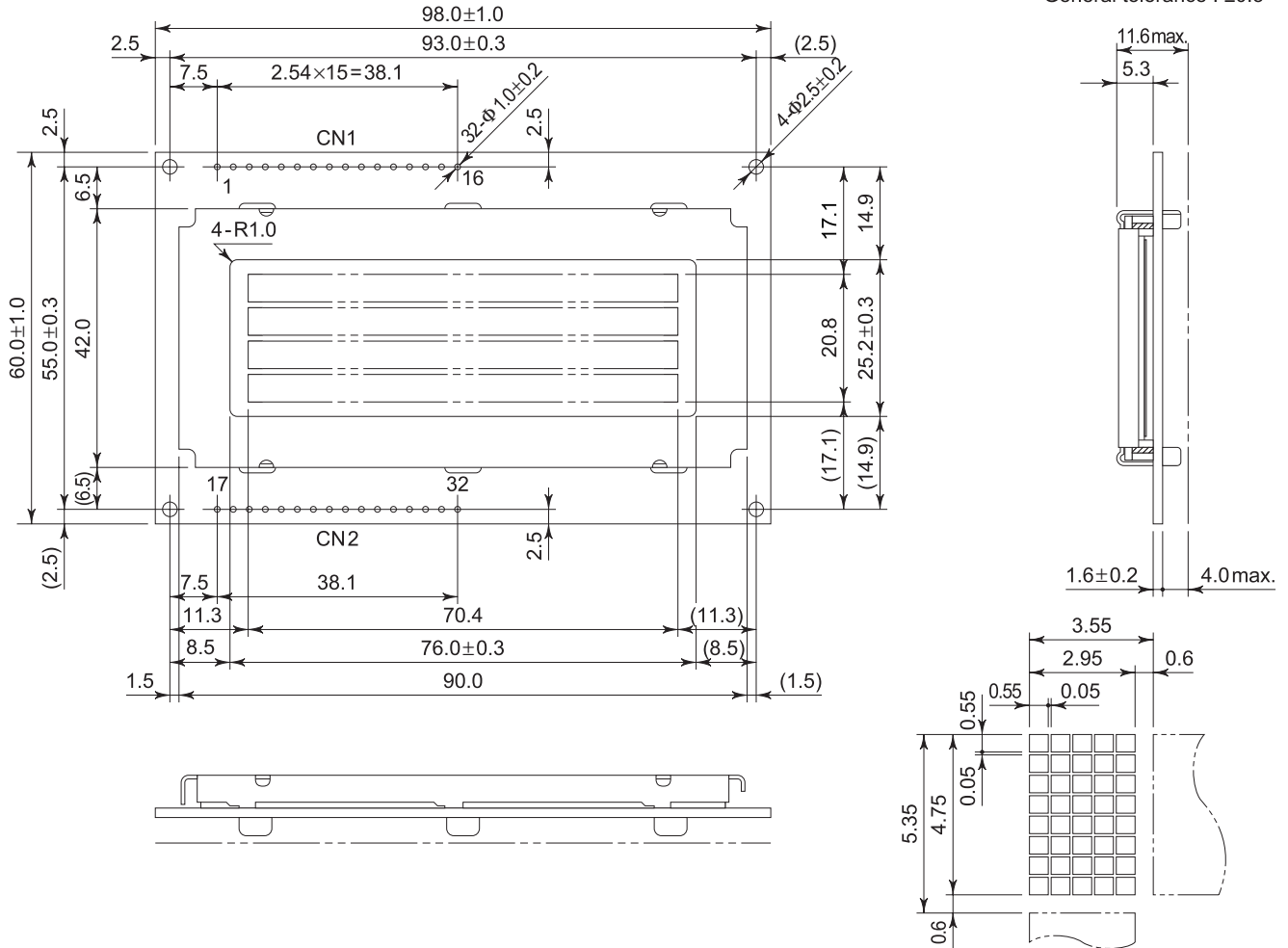

F-3 Pin Functions

No.	No.	Name	Function
1	17	V <sub>SS</sub>	GND
2	18	V <sub>DD</sub>	Power supply voltage +5V
3	19	V <sub>LC</sub>	Liquid crystal driving voltage
4	20	RS	L : Instruction code input H : Data input
5	21	R/W	L : Data write (LCM ← MPU) H : Data read (LCM → MPU)
6	22	E	Enable
7	23	DB <sub>0</sub>	Data bus line
8	24	DB <sub>1</sub>	Data bus line
9	25	DB <sub>2</sub>	Data bus line
10	26	DB <sub>3</sub>	Data bus line
11	27	DB <sub>4</sub>	Data bus line
12	28	DB <sub>5</sub>	Data bus line
13	29	DB <sub>6</sub>	Data bus line
14	30	DB <sub>7</sub>	Data bus line
15	31	NC	—
16	32	NC	—

F-4 Block Diagram

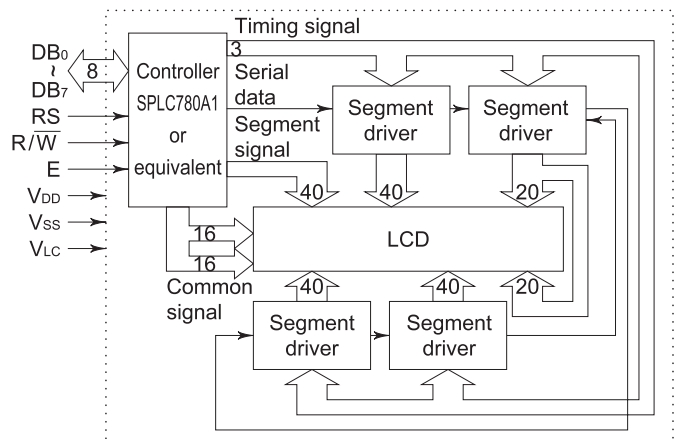

# L2034

■ STN Transflective,  
Built-in LED Backlight type

Item	L2034B1J000
Mechanical Characteristics	A
Absolute Maximum Ratings	B
Electrical Characteristics	C
Optical Characteristics	D-2
Recommended Operating Voltage	E

### G-1 Power Supply

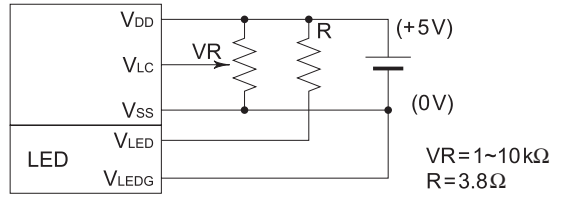

### G-2 Dimensions

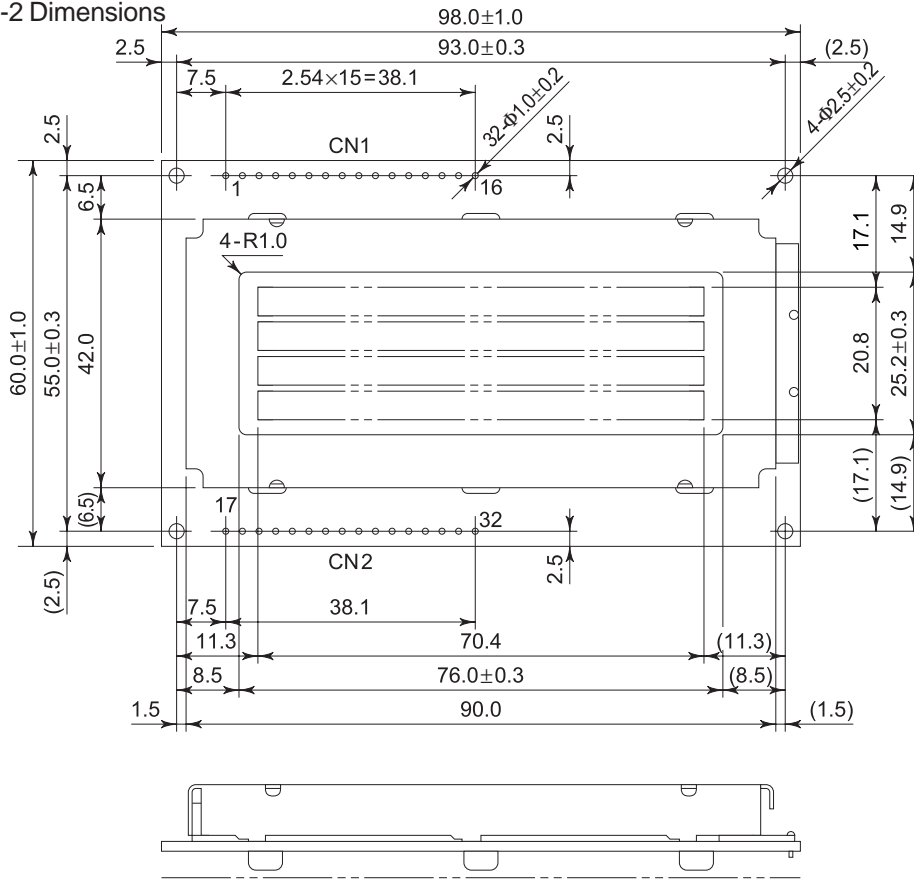

Unit : mm  
General tolerance : ±0.5

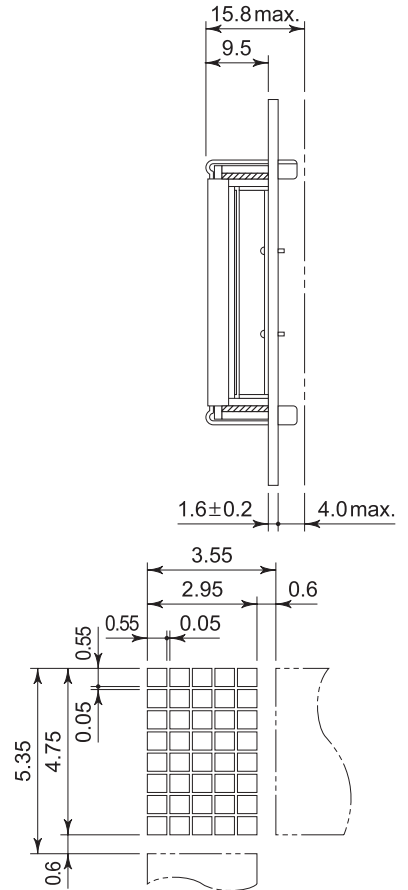

### G-3 Pin Functions

No.	No.	Name	Function
1	17	V <sub>SS</sub>	GND
2	18	V <sub>DD</sub>	Power supply voltage +5V
3	19	V <sub>LC</sub>	Liquid crystal driving voltage
4	20	RS	L : Instruction code input H : Data input
5	21	R/W	L : Data write (LCM ← MPU) H : Data read (LCM → MPU)
6	22	E	Enable
7	23	DB <sub>0</sub>	Data bus line
8	24	DB <sub>1</sub>	Data bus line
9	25	DB <sub>2</sub>	Data bus line
10	26	DB <sub>3</sub>	Data bus line
11	27	DB <sub>4</sub>	Data bus line
12	28	DB <sub>5</sub>	Data bus line
13	29	DB <sub>6</sub>	Data bus line
14	30	DB <sub>7</sub>	Data bus line
15	31	V <sub>LED</sub>	Anode
16	32	V <sub>LEDG</sub>	Cathode

### G-4 Block Diagram

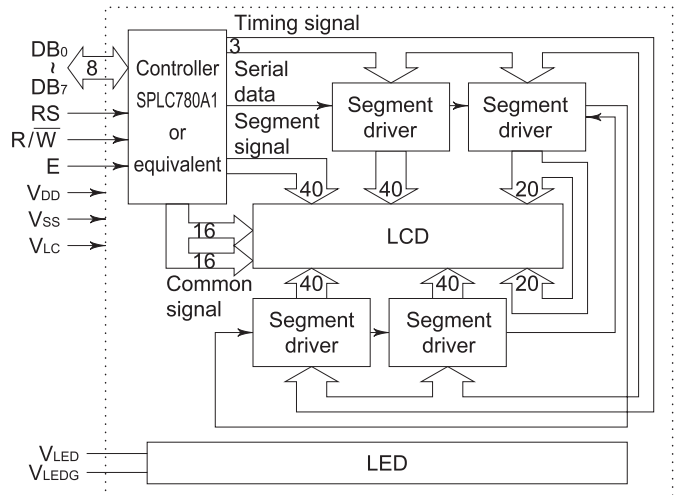

G-5 LED Backlight

G-5-1 LED Circuit Diagram

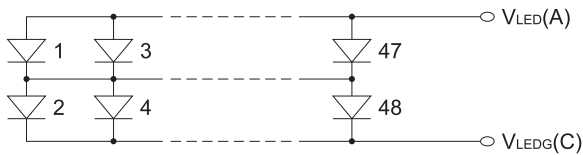

G-5-2 Absolute Maximum Ratings

Ta = 25°C

Item	Symbol	Specifications	Unit
LED forward current consumption*	I <sub>F</sub>	480	mA
LED reverse voltage	V <sub>R</sub>	8	V
LED allowable dissipation	P <sub>D</sub>	2.0	W

\* LED forward current consumption and operating temperature characteristics are as follows.

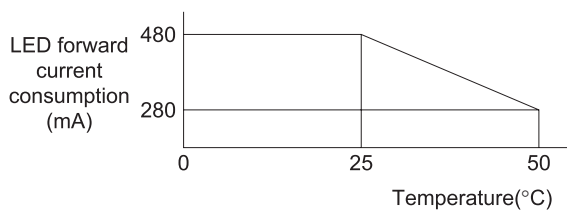

G-5-3 Electrical Characteristics

Ta = 25°C

Item	Symbol	Conditions	Min.	Typ.	Max.	Unit
LED forward input voltage	V <sub>F</sub>	I <sub>F</sub> = 240mA	3.8	4.1	4.4	V
LED reverse current	I <sub>R</sub>	V <sub>R</sub> = 8V	—	—	2.4	mA

G-5-4 Optical Characteristics

Ta = 25°C

Item	Symbol	Conditions	Specifications	Unit
Surface brightness (panel upper side)	B <sub>p</sub>	I <sub>F</sub> = 240mA V <sub>opr</sub> = 0V	4.5 min. 5 typ.	cd/m <sup>2</sup>
LED brightness	L	I <sub>F</sub> = 240mA	40 min. 50 typ.	cd/m <sup>2</sup>
LED service life			50,000 typ.	h
LED color			Yellowgreen	